

MV-IDH9000

Wired Handheld Code Reader



Introduction

The IDH9000 wired handheld code reader adopts code reading algorithm to provide good decoding capability for codes with spots, defects, and low contrast ratio. It has illumination system to provide different types of lighting. The code reader also adopts OLED display for quick viewing of the device and code information, and supports smart tune and quick configuration of code parameters. It is sturdy and durable, resistance to falling and rolling, and also resistance to harsh industrial environment with oil, dust, and water. The code reader is applicable to industries of automobile parts, consumer electronics, PCB, and medical equipment.

Available Model

- Support network interface and serial port (ultra-small code and DPM code):
MV-IDH9000/13HHD/16RP/L
- Support USB interface (ultra-small code and DPM code):
MV-IDH9000/13HHD/16RP/U
- Support network interface and serial port (DPM code with high performance):
MV-IDH9000/13DP/04RP/L
- Support USB interface (DPM code with high performance):
MV-IDH9000/13DP/04RP/U

Applicable Industry

Automobile parts, consumer electronics, semiconductor, PCB, medical equipment, etc.

Key Feature

- Built-in code reading algorithm and illumination system for decoding codes with spots, defects and low contrast ratio.
- The device which supports ultra-small code and DPM code recognition has a lens for reading ultra-small code with a minimum module size of 0.04 mm and a zoom lens for high-speed reading with large depth of field.
- Adopts 4 lighting modes for different scenes, such as direct lighting, polarized lighting, diffused reflection lighting, and bi-directional lighting.
- Sturdy and durable, resistance to falling (2.5 m, 50 times) and rolling (0.5 m, 20000 times), and also resistance to chemical corrosion and strong static electricity interference.
- Adopts OLED display for quick viewing of the device and code information.
- Supports smart tune and quick configuration of code parameters.
- Supports communication protocols, including TCP, FTP, UDP, USB, Profinet, Ethernet/IP, ModBus, Serial, SmartSDK, etc.

Model	MV-IDH9000/13HHD/16RP/L	MV-IDH9000/13HHD/16RP/U
Performance		
Symbologies	1D codes: Code 39, Code 93, Code 128, CodaBar, EAN8, EAN13, ISBN, ISSN, ITF25, ITF14, UPCA, UPCE 2D matrix codes: QR Code, Data Matrix, MicroQR, Aztec Stacked barcode: PDF417	
Min. accuracy	1.57 mil	
Sensor type	CMOS	
Resolution	1280 × 1024	
Depth of field*	Code128 (3 mil): 0 mm to 100 mm ¹ Code 128 (10 mil): 0 mm to 250 mm ¹ Code 128 (20 mil): 0 mm to 350 mm ¹ Code 39 (5 mil): 0 mm to 150 mm ¹ Data Matrix (5 mil): 5 mm to 79 mm QR Code (20 mil): 0 mm to 250 mm ¹	
Field of view	Wide-angle lens: horizontal 43.6°, vertical 35.5° Telephoto lens: horizontal 10.4°, vertical 8.3°	
Detection angle	Tilt angle ± 60°, skew angle ± 60°, rotation angle 360°	
Symbol contrast	20%	
Communication protocol	SmartSDK, UDP, TCP Client, Serial, FTP, TCP Server, Profinet, Ethernet/IP, ModBus	SmartSDK, USB (HID/CDC), Serial ²
Electrical feature		
Data interface	Fast Ethernet (100 Mbit/s), RS-232, DC terminal	USB 2.0, DC terminal
Power supply	DC terminal: 12 VDC PoE ³ : 48 V	12 VDC
Current consumption	DC terminal: 0.7 A (max.), 0.47 A (typical) PoE ³ : 0.2 A (max.), 0.14 A (typical)	0.7 A (max.), 0.47 A (typical)
Mechanical		
Focal length	Wide-angle lens: 4.3 mm Telephoto lens: 16 mm	
Ambient illumination	0 lux to 100000 lux	
Light source	Diffused reflection lighting (red LED), bi-directional lighting (red LED), direct lighting (white LED), polarized lighting (white LED) Smart scanning mode is set by default, and auto polling of lights is supported according to the code reading scene.	
Aiming system	650 nm laser (red light) + LED (green light)	
Prompt	LED indicator, buzzer, vibrator	
Display	0.96" OLED display	
Dimension	74 mm × 109.9 mm × 227.1 mm (2.9" × 4.3" × 8.9")	
Weight	Approx. 490 g (1.1 lb.) (without cable)	
Ingress protection	IP67	
Temperature	Working temperature: -10 °C to 50 °C (14 °F to 122 °F) Storage temperature: -20 °C to 60 °C (-4 °F to 140 °F)	
Humidity	5% RH to 95% RH (no condensation)	
Drop height	Dropping: 2.5 m, 50 times Rolling: 0.5 m, 20000 times	
Chemically resistant	ISO 16750	
Static electricity resistant	± 25 kV (air discharge), ± 10 kV (contact discharge or indirect discharge)	

General	
Client software	IDMVS
Certification	CE, KC

*Test condition: Environment temperature=25 °C (77 °F), ambient illumination=250 lux filament lamp, Hikrobot's test symbologies are used.

1: 0 mm means that the codes can be read within the imaging field of view.

2: If Serial communication protocol should be used for the device with USB interface, you need to purchase a cable with serial port or USB interface separately.

3: PoE power supply is supported by the device with network interface.

Specification

Model	MV-IDH9000/13DP/04RP/L	MV-IDH9000/13DP/04RP/U
Performance		
Symbologies	1D codes: Code 39, Code 93, Code 128, CodaBar, EAN8, EAN13, ISBN, ISSN, ITF25, ITF14, UPCA, UPCE 2D matrix codes: QR Code, Data Matrix, MicroQR, Aztec Stacked barcode: PDF417	
Min. accuracy	3 mil	
Sensor type	CMOS	
Resolution	1280 × 1024	
Depth of field*	Code128 (3 mil): 0 mm to 100 mm ¹ Code 128 (10 mil): 0 mm to 250 mm ¹ Code 128 (20 mil): 0 mm to 350 mm ¹ Code 39 (5 mil): 0 mm to 150 mm ¹ Data Matrix (5 mil): 5 mm to 75 mm QR Code (20 mil): 0 mm to 250 mm ¹	
Field of view	Horizontal 43.6°, vertical 35.5°	
Detection angle	Tilt angle ± 60°, skew angle ± 60°, rotation angle 360°	
Symbol contrast	20%	
Communication protocol	SmartSDK, UDP, TCP Client, Serial, FTP, TCP Server, Profinet, Ethernet/IP, ModBus	SmartSDK, USB (HID/CDC), Serial ²
Electrical feature		
Data interface	Fast Ethernet (100 Mbit/s), RS-232, DC terminal	USB 2.0, DC terminal
Power supply	DC terminal: 12 VDC PoE ³ : 48 V	12 VDC
Current consumption	DC terminal: 0.7 A (max.), 0.47 A (typical) PoE ³ : 0.2 A (max.), 0.14 A (typical)	0.7 A (max.), 0.47 A (typical)
Mechanical		
Focal length	4.3 mm	
Ambient illumination	0 lux to 100000 lux	
Light source	Diffused reflection lighting (red LED), bi-directional lighting (red LED), direct lighting (white LED), polarized lighting (white LED) Smart scanning mode is set by default, and auto polling of lights is supported according to the code reading scene.	
Aiming system	650 nm laser (red light)	
Prompt	LED indicator, buzzer, vibrator	
Display	0.96" OLED display	

Dimension	74 mm × 109.9 mm × 227.1 mm (2.9" × 4.3" × 8.9")
Weight	Approx. 488 g (1.1 lb.) (without cable)
Ingress protection	IP67
Temperature	Working temperature: -10 °C to 50 °C (14 °F to 122 °F) Storage temperature: -20 °C to 60 °C (-4 °F to 140 °F)
Humidity	5% RH to 95% RH (no condensation)
Drop height	Dropping: 2.5 m, 50 times Rolling: 0.5 m, 20000 times
Chemically resistant	ISO 16750
Static electricity resistant	± 25 kV (air discharge), ± 10 kV (contact discharge or indirect discharge)
General	
Client software	IDMVS
Certification	CE, KC

*Test condition: Environment temperature=25 °C (77 °F), ambient illumination=250 lux filament lamp, Hikrobot's test symbologies are used.

1: 0 mm means that the codes can be read within the imaging field of view.

2: If Serial communication protocol should be used for the device with USB interface, you need to purchase a cable with serial port or USB interface separately.

3: PoE power supply is supported by the device with network interface.

Laser Information of IDH 9000 Series Product	
Laser safety class	Laser 2
Wavelength	650 nm
Pulse width	6.6 ms
Maximum power	1 mW

Dimension

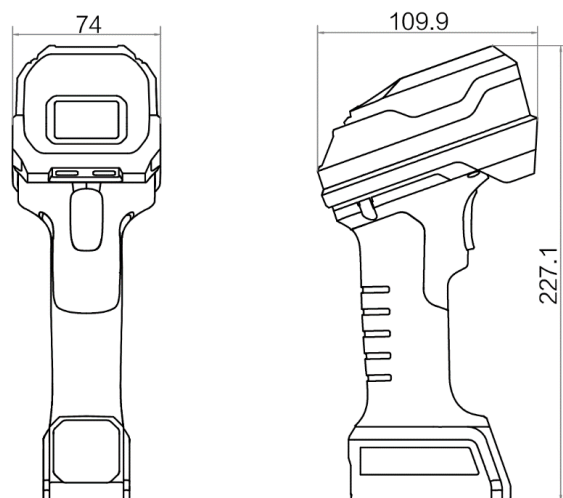

Unit: mm