

MV-SC6500-AI-WID

Smart Camera



Introduction

MV-SC6500-AI-WID smart camera is developed based on high-performance embedded platform with strong calculation performance. It integrates AI recognition algorithm and multiple lighting methods to recognize wafer ID information. It adopts multiple interfaces for calculation performance. It integrates AI recognition algorithm and multiple lighting methods to recognize wafer ID information. It adopts multiple interfaces for supporting external display, keyboard, mouse, etc

Available Model

MV-SC6500-AI-WID

Dimension

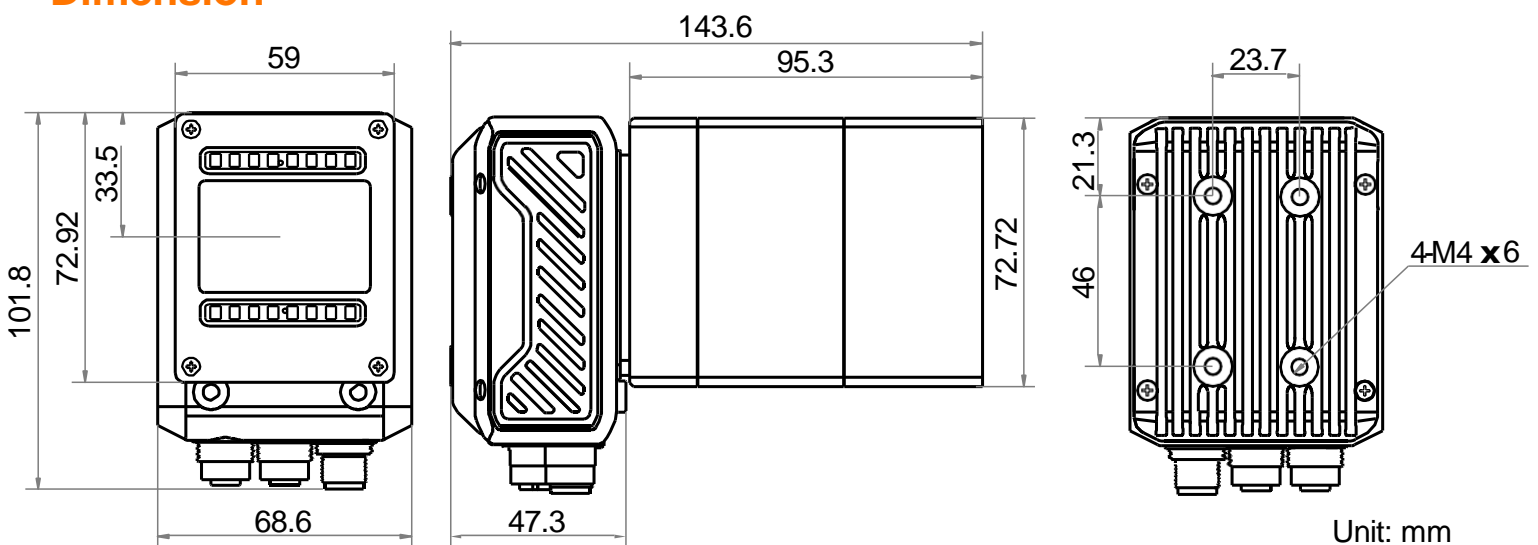

Key Feature

- Adopts AI algorithm to recognize wafer ID information. Supports advanced optical imaging system with multiple lighting methods.
- Integrates VM functions and supports more than 140 algorithms.
- Adopts multiple interfaces and supports multiple-channel I/O, display, keyboard, mouse etc.
- Adopts high-performance CPU with faster calculation performance and high efficiency.
- Supports multiple communication protocols.
- Supports indicators displaying device status for easy debugging and maintenance.

Specification

Model	MV-SC6500-AI-WID
Tool	
Function module	VM Platform
Algorithm capability	SEMI OCR character, data matrix code, QR code, and barcode
Communication protocol	TCP, UDP, ModBus, Serial Port, Profinet, EtherNet/IP, Fins, MC, FTP, etc.
Camera	
Sensor type	CMOS, global shutter
Pixel size	3.45 μm × 3.45 μm
Sensor size	1/2.9"
Resolution	1408 × 1024
Max. frame rate	60 fps
Gain	0 dB to 15 dB
Exposure time	16 μs to 1 sec
Pixel format	Mono 8
Mono/color	Mono
Light source	
LED	Red LED
Lighting method	Multiple lighting methods (bright field lighting and dark field lighting)
Illumination intensity	Configure in software
Indicator	Power indicator (PWR), network indicator (LNK), user-defined indicator (U1/U2), and result indicator (OK/NG)
Lens and installation	
Lens mount	M12 mount
Lens cap	Transparent lens cap
Focus mode	Auto
Installation height	40 mm to 50 mm (recommended)
Field of view (range)	36 mm × 20 mm
Depth of field	±5 mm
Platform	
Memory	8 GB
Storage	64 GB

Model	MV-SC6500-AI-WID
<i>Electrical feature</i>	
Data interface	Gigabit Ethernet (1000 Mbit/s)
Digital I/O	17-pin M12 connector provides opto-isolated input × 2 (Line 0/1), opto-isolated output × 2 (Line 4/5), configurable non-isolated input/output × 2 (Line 2/3), RS-232 × 1
Extended interface	VGA × 1 and USB host × 1
Power supply	24 VDC
Power consumption	Typ. 16.5 W @ 24 VDC
<i>Mechanical</i>	
Dimension	143.6 mm × 68.6 mm × 101.8 mm (5.6" × 2.7" × 4.0")
Weight	Approx. 820 g (1.8 lb.)
Ingress protection	IP40 (under proper installation of waterproof lens cap)
Temperature	Working temperature: 0 °C to 40 °C (32 °F to 104 °F) Storage temperature: -30 °C to 70 °C (-22 °F to 158 °F)
Humidity	20% RH to 95% RH, non-condensing
<i>General</i>	
Certification	CE, KC