

MV-CH210-90Q2M

21MP XoFLink Area Scan Camera



GEN*i*CAM

Introduction

MV-CH210-90Q2M camera adopts Gpixel Gsprint4521 CMOS sensor to provide high-quality images. It is equipped with two QSFP+ ports to transmit non-compressed data in real time, and its max. frame rate can reach 541 fps in full resolution.

Key Feature

- Resolution of 5120 × 4096, pixel size of 4.5 μm.
- Adopts global shutter CMOS sensor to provide high dynamic range, SNR, and high-quality image.
- Supports ISP functions such as Binning and multi-group polling for LSC.
- Supports data transmission through two 50 Gbps fiber ports.
- Features an M58 mount; can be adapted to F-mount lenses via an adapter ring.

Dimension

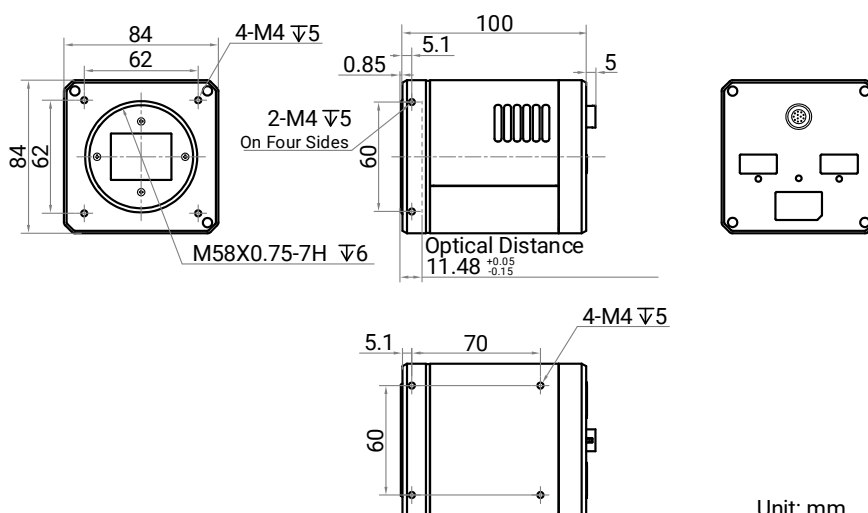

Unit: mm

Available Model

MV-CH210-90Q2M-M58S-NF

Applicable Industry

PCB AOI, 3D applications, electronic semiconductor, motion capture, etc.

Sensor Quantum

Efficiency

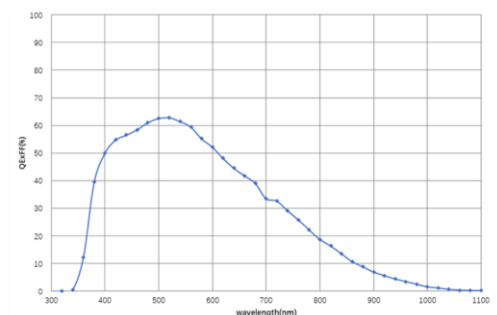

Accessories

- 50 Gbps Fiber Port Frame Grabber: MV-GQ1001 (without optical module)
- Optical Module of Fiber Port Frame Grabber: MV-AC100G-QSFP28
- Optical Fiber Patch Cord: MV-AC100G-MPO-MPO-ST

Specification

Model	MV-CH210-90Q2M
Performance	
Sensor type	CMOS, global shutter
Sensor model	Gpixel Gsprint4521
Pixel size	4.5 μm × 4.5 μm
Sensor size	23.04 mm × 18.43 mm
Resolution	5120 × 4096
Max. frame rate	541 fps @ 5120 × 4096 Mono 8
Dynamic range	65 dB
SNR	43 dB
Gain	1.0 x, 2.0 x, 4.0 x
Exposure time	1 μs to 10 sec
Exposure mode	Off/Once/Continuous exposure mode
Mono/color	Mono
Pixel format	Mono 8
Binning	Supports 1 × 1, 1 × 2, 1 × 4, 2 × 1, 2 × 2, 2 × 4, 4 × 1, 4 × 2, 4 × 4
Decimation	Supports 1 × 1, 1 × 2, 1 × 4, 2 × 1, 2 × 2, 2 × 4, 4 × 1, 4 × 2, 4 × 4
Reverse image	Supports horizontal and vertical reverse image output
Electrical feature	
Data interface	QSFP+ × 2
Digital I/O	12-pin P10 connector provides power and I/O, including opto-isolated input × 1 (Line 0), opto-isolated output × 1 (Line 1), bi-directional non-isolated I/O × 1 (Line 2), RS-232 × 1.
Power supply	12 VDC to 24 VDC
Power consumption	Typ. 33 W @ 24 VDC
Mechanical	
Lens mount	M58 × 0.75
Dimension (without lens)	84 mm × 84 mm × 100 mm (3.3" × 3.3" × 3.9")
Weight	Approx. 1153 g (2.5 lb.)
Ingress protection	IP40 (under proper lens installation and wiring)
Temperature	Working temperature: 0 °C to 40 °C (32 °F to 104 °F) Storage temperature: -30 °C to 80 °C (-22 °F to 176 °F)
Humidity	20% RH to 95% RH (no condensation)
General	
Client software	MVS
Operating system	32/64-bit Windows 7/10/11
Compatibility	XoFLink protocol, GenICam
Certification	RoHS