

CH Series Area Scan Camera

High-end product series designed for high-precision application and development in Panel, electronic semiconductor, new energy and other industries. which covers data interfaces of GigE, USB 3.0, 10 GigE, Camera Link, CoaXPress, XoFLink.

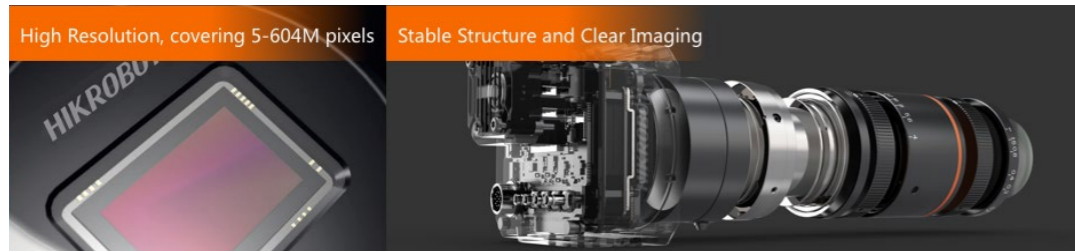

High-end area scan camera with high resolution coverage

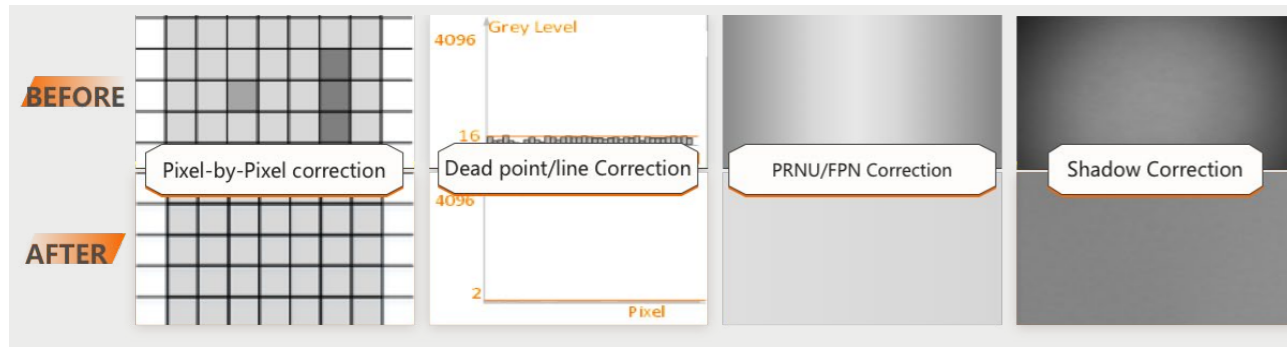

Rich ISP algorithm

CH Series GigE Area Scan Camera



Dimension

Model	Sensor model	Sensor size	Pixel size	Shutter mode	Resolution	Max. frame rate	Exposure time	Power consumption	Lens mount	Label
MV-CH089-106M	IMX267	1"	3.45 μm	Global	4096 × 2160	13.7 fps	USE: 1 μs-14 μs NE: 15 μs-10 sec	Typ. 2.3 W@12 VDC	C	A
MV-CH089-106C	IMX267	1"	3.45 μm	Global	4096 × 2160	13.7 fps	USE: 1 μs-14 μs NE: 15 μs-10 sec	Typ. 2.4 W@12 VDC	C	A
MV-CH100-606M	HK	1"	3.45 μm	Global	4096 × 2460	12 fps	NE: 80 μs-10 sec	Typ. 3.1 W@12 VDC	C	B
MV-CH100-606C	HK	1"	3.45 μm	Global	4096 × 2460	12 fps	NE: 80 μs-10 sec	Typ. 3.5 W@12 VDC	C	B
MV-CH120-106M	IMX304	1.1"	3.45 μm	Global	4096 × 3000	9.4 fps	USE: 1 μs-14 μs NE: 15 μs-10 sec	Typ. 2.9 W@12 VDC	C	A
MV-CH120-106C	IMX304	1.1"	3.45 μm	Global	4096 × 3000	9.4 fps	USE: 1 μs-14 μs NE: 15 μs-10 sec	Typ. 3.0 W@12 VDC	C	A
MV-CH120-206M	XGS12000	1"	3.2 μm	Global	4096 × 3072	9.6 fps	USE: 52 μs-161 μs NE: 162 μs-10 sec	Typ. 2.6 W@12 VDC	C	A
MV-CH120-206C	XGS12000	1"	3.2 μm	Global	4096 × 3072	9.6 fps	USE: 52 μs-161 μs NE: 162 μs-10 sec	Typ. 2.7 W@12 VDC	C	A

Model	Sensor model	Sensor size	Pixel size	Shutter mode	Resolution	Max. frame rate	Exposure time	Power consumption	Lens mount	Label
MV-CH123-106M *	IMX545	1/1.1"	2.74 μm	Global	4096 × 3000	9.5 fps	USE: 3 μs-33 μs NE: 36 μs-2 S	Typ. 2.9 W@12 VDC	C	A
MV-CH123-106C *	IMX545	1/1.1"	2.74 μm	Global	4096 × 3000	9.5 fps	USE: 3 μs-33 μs NE: 36 μs-2 S	Typ. 3.0 W@12 VDC	C	A
MV-CH140-606M	HK	1"	3 μm	Global	4708 × 2824	9 fps	NE: 80 μs-10 sec	Typ. 3.0 W@12 VDC	C	B
MV-CH140-606C	HK	1"	3 μm	Global	4708 × 2824	9 fps	NE: 80 μs-10 sec	Typ. 3.5 W@12 VDC	C	B
MV-CH160-606M	HK	1.1"	3.2 μm	Global	4000 × 4000	7.25 fps	NE: 12 μs-10 sec	Typ. 3.72 W@12 VDC	C	B
MV-CH250-906M	GMAX0505	1.1"	2.5 μm	Global	5120 × 5120	4.5 fps	NE: 12 μs-10 sec	Typ. 3.1 W@12 VDC	C	B
MV-CH250-906C	GMAX0505	1.1"	2.5 μm	Global	5120 × 5120	4.5 fps	NE: 12 μs-10 sec	Typ. 3.2 W@12 VDC	C	B
MV-CH250-906N	GMAX0505	1.1"	2.5 μm	Global	5120 × 5120	4.5 fps	NE: 12 μs-10 sec	Typ. 3.1 W@12 VDC	C	B
MV-CH310-106M	IMX342	22.3 mm × 16.7 mm	3.45 μm	Global	6464 × 4852	3.9 fps	USE: 3 μs-33 μs NE: 36 μs-2 Sec	Typ. 9 W@12 VDC	F M58	C D
MV-CH310-106C	IMX342	22.3 mm × 16.7 mm	3.45 μm	Global	6464 × 4852	3.9 fps	USE: 3 μs-33 μs NE: 36 μs-10 Sec	Typ. 9 W@12 VDC	F M58	C D

Notice: * will be released soon, please consult details with sales representative
 USE: Ultra-short exposure mode
 NE: Normal exposure mode

Dimension

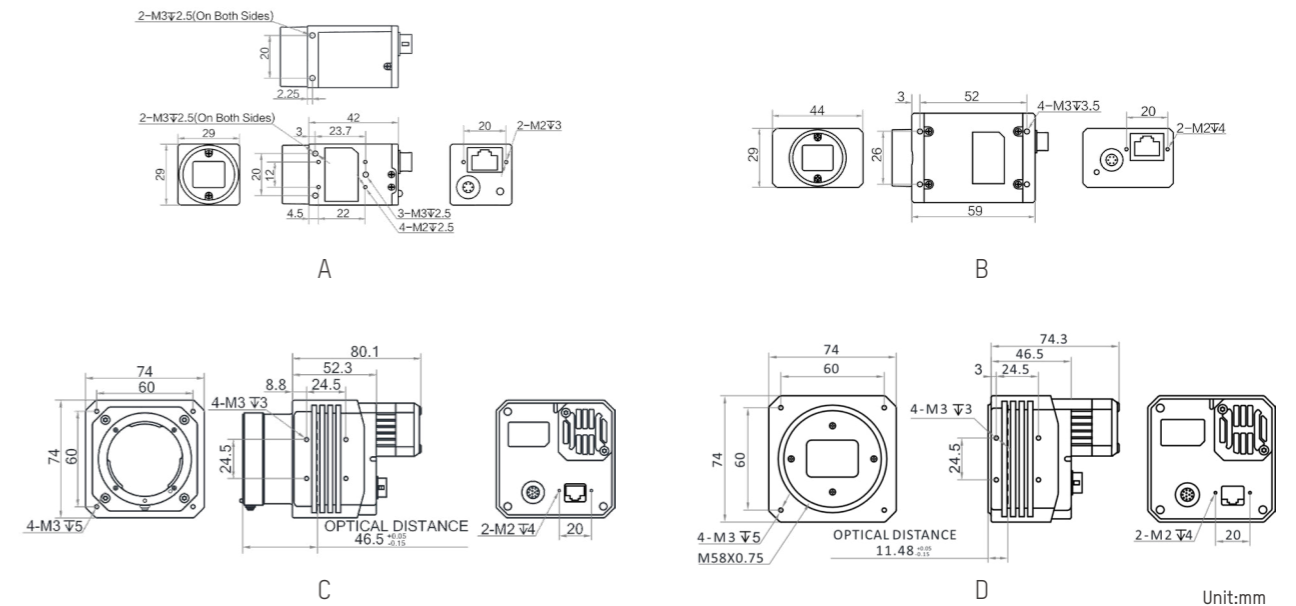

CH Series USB3.0 Area Scan Camera

Specifications

Model	Sensor model	Sensor size	Pixel size	Shutter mode	Resolution	Max. frame rate	Exposure time	Power consumption	Lens mount	Label
MV-CH050-10UM	IMX250	2/3"	3.45 μm	Global	2448 × 2048	74.1 fps	USE: 1 μs-14 μs NE: 15 μs-10 sec	Typ. 3.3 W@5 VDC	C	A
MV-CH050-10UC	IMX250	2/3"	3.45 μm	Global	2448 × 2048	74.1 fps	USE: 1 μs-14 μs NE: 15 μs-10 sec	Typ. 2.8 W@5 VDC	C	A
MV-CH050-10UP	IMX250	2/3"	3.45 μm	Global	2448 × 2048	74.1 fps	USE: 1 μs-14 μs NE: 15 μs-10 sec	Typ. 3.3 W@5 VDC	C	A
MV-CH089-10UM	IMX267	1"	3.45 μm	Global	4096 × 2160	32 fps	USE: 1 μs-14 μs NE: 15 μs-10 sec	Typ. 3.27 W@5 VDC	C	B
MV-CH089-10UC	IMX267	1"	3.45 μm	Global	4096 × 2160	32 fps	USE: 1 μs-14 μs NE: 15 μs-10 sec	Typ. 3.27 W@5 VDC	C	B
MV-CH120-10UM	IMX304	1.1"	3.45 μm	Global	4096 × 3000	30.5 fps	USE: 1 μs-14 μs NE: 15 μs-10 sec	Typ. 2.9 W@5 VDC	C	A
MV-CH120-10UC	IMX304	1.1"	3.45 μm	Global	4096 × 3000	30.5 fps	USE: 1 μs-14 μs NE: 15 μs-10 sec	Typ. 2.9 W@5 VDC	C	A
MV-CH120-20UM	XGS12000	1"	3.2 μm	Global	4096 × 3072	28 fps	USE: 52 μs-161 μs NE: 162 μs-10 sec	Typ. 2.9 W@5 VDC	C	A
MV-CH120-20UC	XGS12000	1"	3.2 μm	Global	4096 × 3072	28 fps	USE: 10 μs-56 μs NE: 57 μs-10 sec	Typ. 3.2 W@5 VDC	C	A
MV-CH123-10UM *	IMX545	1/1.1"	2.74 μm	Global	4096 × 3000	28 fps	USE: 3 μs-33 μs NE: 36 μs-2 sec	Typ. 3.5 W@5 VDC	C	A
MV-CH123-10UC *	IMX545	1/1.1"	2.74 μm	Global	4096 × 3000	28 fps	USE: 3 μs-33 μs NE: 36 μs-2 sec	Typ. 3.5 W@5 VDC	C	A
MV-CH250-90UM	GMAX0505	1.1"	2.5 μm	Global	5120 × 5120	14 fps	NE: 12 μs-10 sec	Typ. 3.6 W@5 VDC	C	B
MV-CH250-90UC	GMAX0505	1.1"	2.5 μm	Global	5120 × 5120	14 fps	NE: 12 μs-10 sec	Typ. 3.6 W@5 VDC	C	B
MV-CH250-90VM *	GMAX0505	1.1"	2.5 μm	Global	5120 × 5120	30 fps	NE: 12 μs-10 sec	Typ. 4.5 W@5 VDC	C	C

Notice: * will be released soon, please consult details with sales representative
P=Polarization
USE: Ultra-short exposure mode
NE: Normal exposure mode

Dimension

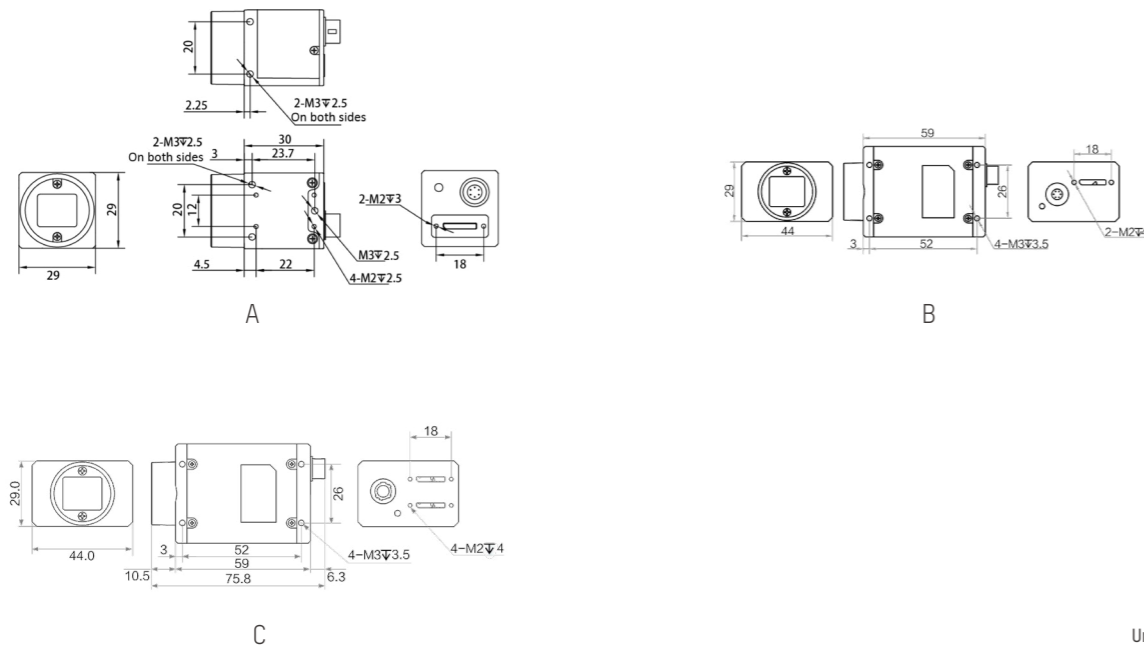

Unit:mm

CH Series 10GigE Area Scan Camera

Specifications

Model	Sensor model	Sensor size	Pixel size	Shutter mode	Resolution	Max. frame rate	Exposure time	Power consumption	Lens mount	Label
MV-CH120-15TM	IMX253	1.1"	3.45 μm	Global	4096 × 3000	68.3 fps	USE: 2 μs-14 μs NE: 15 μs-10 sec	Typ. 9.6 W@24 VDC	M58	A
MV-CH120-15TC	IMX253	1.1"	3.45 μm	Global	4096 × 3000	68.3 fps	USE: 2 μs-14 μs NE: 15 μs-10 sec	Typ. 10.1 W@24 VDC	M58	A
MV-CH240-10TM	IMX540	1.2"	2.74 μm	Global	5328 × 4600	35.1 fps	USE: 1 μs-7 μs NE: 8 μs-10 sec	Typ. 10 W@12 VDC	M58 C	B C
MV-CH250-60TM	HK	23 mm × 23 mm	4.5 μm	Global	5120 × 5120	31.7 fps	NE: 15 μs-10 sec	Typ. 15.1W@12 VDC	M58	D
MV-CH250-90TM	GMAX0505	1.1"	2.5 μm	Global	5120 × 5120	41.5 fps	NE: 13 μs to 10 sec	Typ. 9.7 W@12 VDC	M58 C	E F
MV-CH250-90TC	GMAX0505	1.1"	2.5 μm	Global	5120 × 5120	41.5 fps	NE: 13 μs to 10 sec	Typ. 9.7 W@12 VDC	M58 C	E F
MV-CH310-10TM	IMX342	22.3 mm × 16.7 mm	3.45 μm	Global	6464 × 4852	17.2 fps	NE: 4 μs-10 sec	Typ. 11.5 W@12 VDC	M58	G
MV-CH310-10TC	IMX342	22.3 mm × 16.7 mm	3.45 μm	Global	6464 × 4852	17.2 fps	NE: 4 μs-10 sec	Typ. 11.5 W@12 VDC	M58	G
MV-CH500-90TM	GMAX	22.4 mm × 22.4 mm	3.2 μm	Global	7008 × 7000	15.5 fps	NE: 15 μs-10 sec	Typ. 11 W@12 VDC	M58	D
MV-CH500-90TC	GMAX	22.4 mm × 22.4 mm	3.2 μm	Global	7008 × 7000	15.5 fps	NE: 15 μs-10 sec	Typ. 12 W@12 VDC	M58	D
MV-CH650-90TM	GMAX3265	29.9 mm × 22.4 mm	3.2 μm	Global	9344 × 7000	17.2 fps	NE: 18 μs-10 sec	Typ. 10.2 W@12 VDC	M58 F	D H
MV-CH650-90TC	GMAX3265	29.9 mm × 22.4 mm	3.2 μm	Global	9344 × 7000	17.2 fps	NE: 18 μs-10 sec	Typ. 11.6 W@12 VDC	M58 F	D H
MV-CH1030-90TM *	GMAX32103	36.1 mm × 29.4 mm	3.2 μm	Global	11276 × 9200	10fps	15 μs-10 sec	Typ. 15 W@12 VDC	M58	B
MV-CH1030-90TMC *	GMAX32103	36.1 mm × 29.4 mm	3.2 μm	Global	11276 × 9200	10fps	15 μs-10 sec	Typ. 15 W@12 VDC	M58	B
MV-CH1510-10FM	IMX411	66.7 mm	3.76 μm	Rolling	14208 × 10640	6.2 fps	NE: 30 μs-10 sec	TEC off: Typ. 11.3 W @24 VDC TEC on: Typ. 49 W @24 VDC	M72	I

Notice: * will be released soon, please consult details with sales representative
USE: Ultra-short exposure mode
NE: Normal exposure mode

Dimension

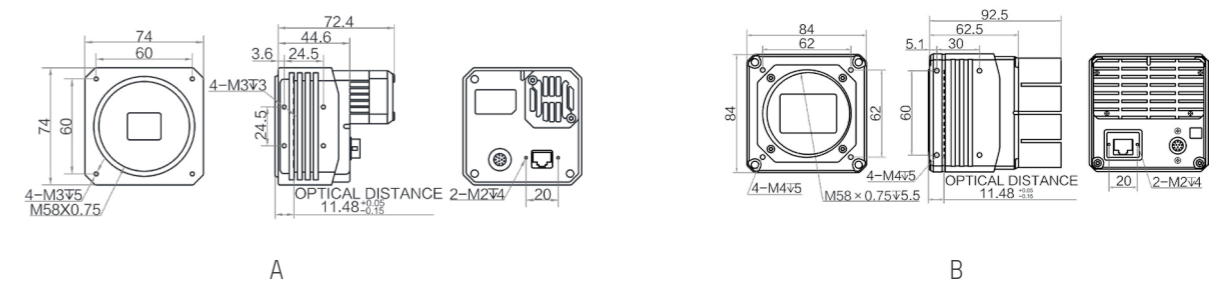

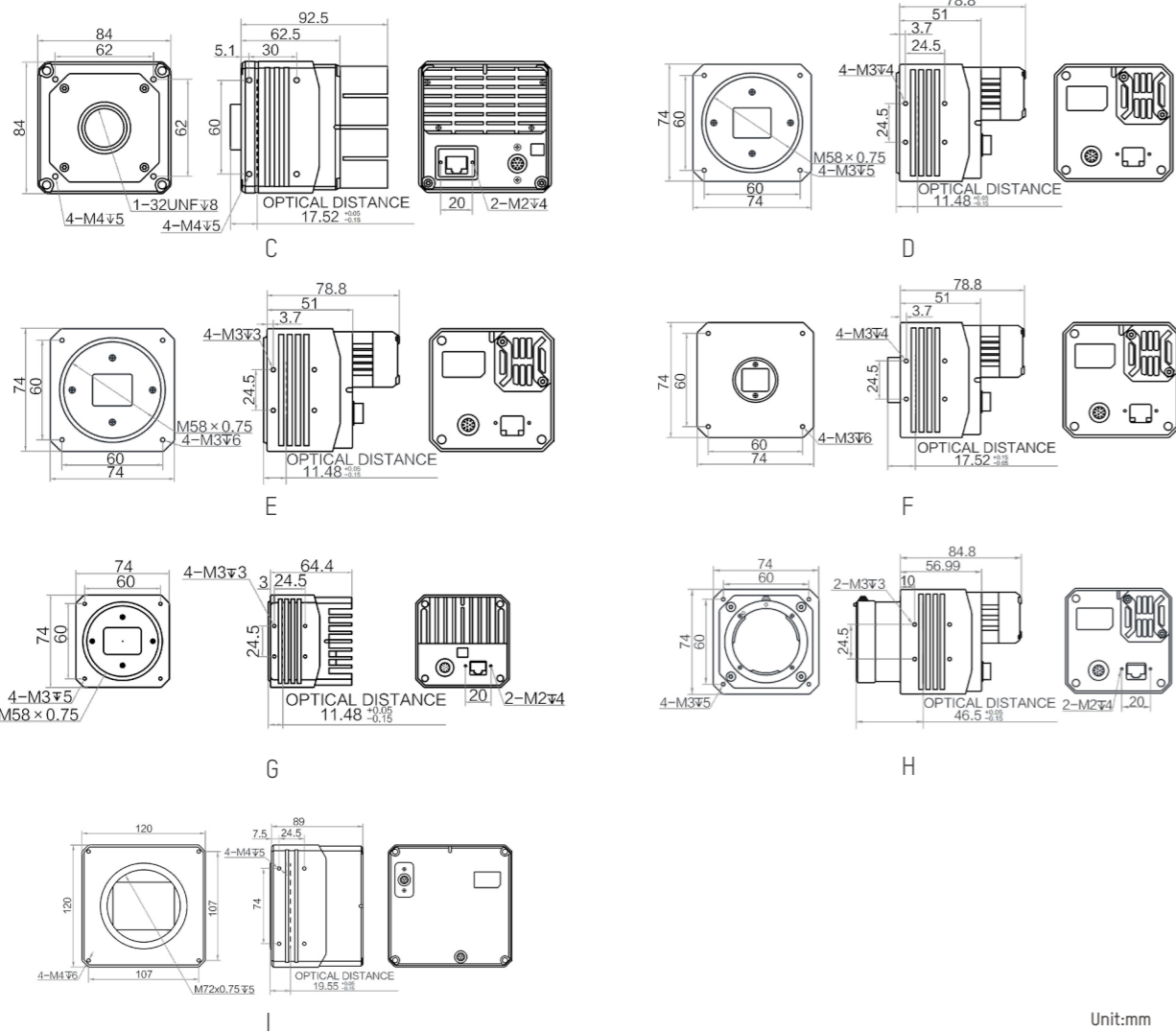

Unit:mm

CH Series Camera Link Area Scan Camera

Specifications

Model	Sensor model	Sensor size	Pixel size	Shutter mode	Resolution	Max. frame rate	Exposure time	Power consumption	Lens mount	Label
MV-CH040-A0CM	HK	1"	5.5µm	Global	2048 × 2048	180 fps	NE: 34 µs-10 sec	Typ. 3.5 W@12 VDC	C	A
MV-CH050-10CM	IMX250	2/3"	3.45 µm	Global	2432 × 2048	140 fps	NE: 15 µs-10 sec	Typ. 3.3 W@12 VDC	C	A
MV-CH050-10CC	IMX250	2/3"	3.45 µm	Global	2432 × 2048	140 fps	NE: 15 µs-10 sec	Typ. 3.41 W@12 VDC	C	A
MV-CH050-11CM	IMX264	2/3"	3.45 µm	Global	2448 × 2048	35 fps	NE: 15 µs-10 sec	Typ. 3.25 W@12 VDC	C	A
MV-CH120-10CM	IMX253	1.1"	3.45 µm	Global	3840 × 3000	69.8 fps	NE: 1 µs-10 sec	Typ. 4.51 W@12 VDC	C	A
MV-CH120-10CC	IMX253	1.1"	3.45 µm	Global	3840 × 3000	68.1 fps	NE: 1 µs-10 sec	Typ. 4.5 W@12 VDC	C	A
MV-CH120-11CM	IMX304	1.1"	3.45 µm	Global	4096 × 3000	23.4 fps	USE: 1 µs-14 sec NE: 15 µs-10 sec	Typ. 3.48 W@12 VDC	C	A
								Typ. 14 W@24 VDC		B
MV-CH1010-10CM	IMX461	55 mm	3.76 µm	Rolling	11648 × 8740	8.1 fps	NE: 14µs-10 sec	TEC off: Typ. 14 W@24 VDC TEC on: Typ. 48 W@24 VDC	M72	C
MV-CH1010-10CC	IMX461	55 mm	3.76 µm	Rolling	11648 × 8740	8.1 fps	NE: 14µs-10 sec	TEC off: Typ. 14 W@24 VDC TEC on: Typ. 48 W@24 VDC	M72	C

Notice: USE: Ultra-short exposure mode
NE: Normal exposure mode



Dimension

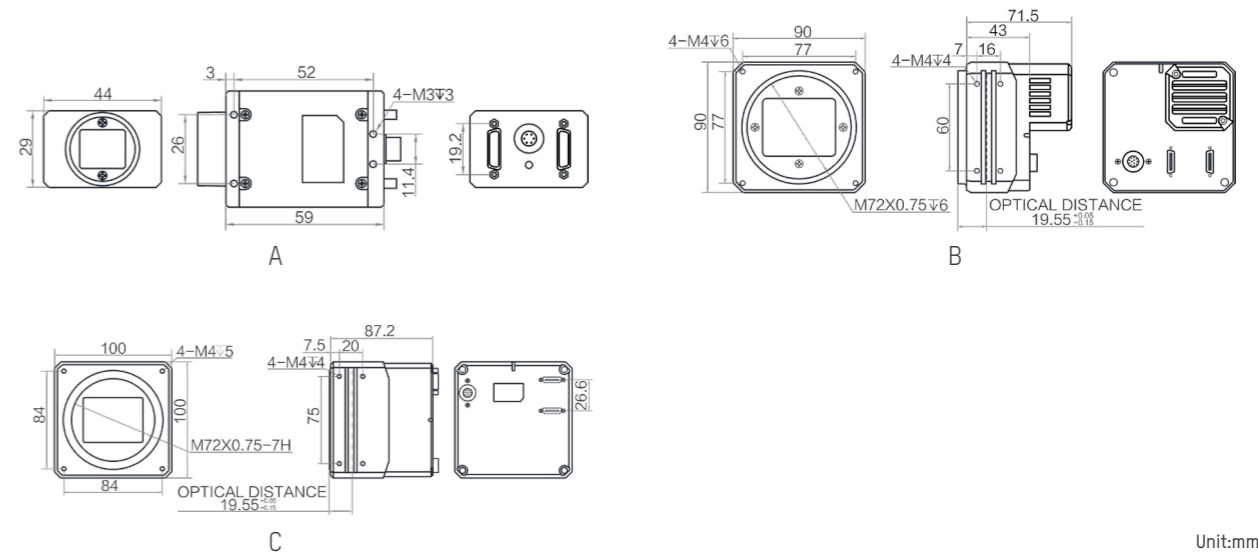

Unit:mm

CH Series CoaXPress Area Scan Camera



Specifications

Model	Sensor model	Sensor size	Pixel size	Shutter mode	Resolution	Max. frame rate	Exposure time	Power consumption	Lens mount	Label
MV-CH050-90XM	GMAX2505	1/2"	2.5 µm	Global	2592 × 2160	213 fps	5 µs-10 sec	Typ. 5.3 W@12 VDC	C	A
MV-CH120-40XM	CMV12000	22.5 mm × 16.9 mm	5.5µm	Global	4096 × 3072	188 fps	34 µs-10 sec	Typ. 10 W@12 VDC	M58	B
MV-CH210-90YM	Gsprint 4521	23.04 mm × 18.43 mm	4.5 µm	Global	5120 × 4096	222 fps	4 µs-10 sec	Typ. 18 W@24 VDC	M58	C
MV-CH210-90YC	Gsprint 4521	23.04 mm × 18.43 mm	4.5 µm	Global	5120 × 4096	222 fps	4 µs-10 sec	Typ. 16.3 W@24 VDC	M58	C
MV-CH250-90XM	GMAX0505	1.1"	2.5 µm	Global	5120 × 5120	41.5 fps	13 µs-10 sec	Typ. 7.0 W@12 VDC	C	A
MV-CH250-90YM	GMAX0505	1.1"	2.5 µm	Global	5120 × 5120	150 fps	13 µs-10 sec	Typ. 13.7 W@12 VDC	M58 C	D E
MV-CH250-90YM V2.0	GMAX0505	1.1"	2.5 µm	Global	5120 × 5120	150 fps	USE: 3 µs-8 sec NE: 10 µs-10 sec	Typ. 9.9 W@12 VDC	M58	B
MV-CH250-90YC	GMAX0505	1.1"	2.5 µm	Global	5120 × 5120	150 fps	13 µs-10 sec	Typ. 13.7 W@12 VDC	M58 C	D E
MV-CH500-90XM	GMAX	22.4 mm × 22.4 mm	3.2 µm	Global	7008 × 7000	31.5 fps	14 µs-10 sec	Typ. 10.5 W@12 VDC	M58	F
MV-CH500-90YM	GMAX	22.4 mm × 22.4 mm	3.2 µm	Global	7008 × 7000	71 fps	14 µs-10 sec	Typ. 13 W@12 VDC	M58	B
MV-CH650-90XM	GMAX3265	29.9 mm × 22.4 mm	3.2 µm	Global	9344 × 7000	31.5 fps	14 µs-10 sec	Typ. 10.5 W@12 VDC	M58 F	F G
MV-CH650-90XC	GMAX3265	29.9 mm × 22.4 mm	3.2 µm	Global	9344 × 7000	31.5 fps	14 µs-10 sec	Typ. 10.5 W@12 VDC	M58 F	F G
MV-CH650-90YM	GMAX3265	29.9 mm × 22.4 mm	3.2 µm	Global	9344 × 7000	71 fps	15 µs-10 sec	Typ. 13.0 W@12 VDC	M58	C

