

Laser Sensors

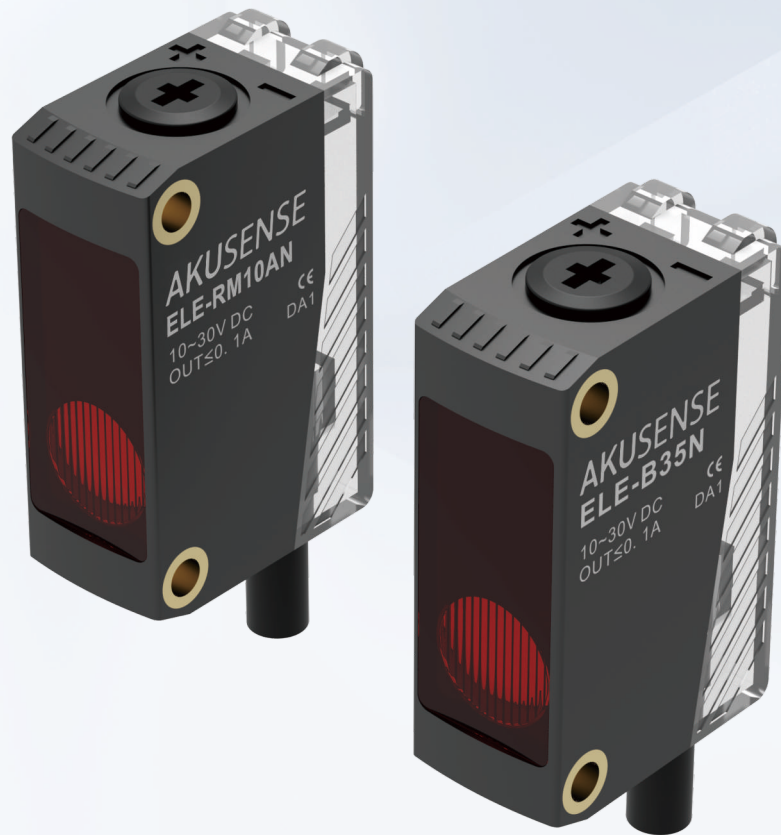

- Utilizes custom-developed integrated circuits and optical design
- Ultra-small light spots (minimum 1mm), Achieved High-Precision Detection

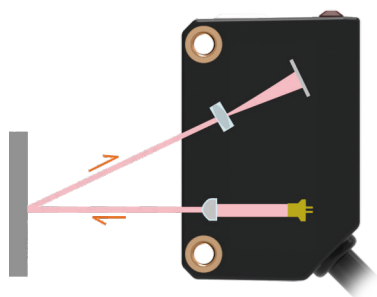

Unique Product Design

Utilizes custom-developed integrated circuits and optical designs
Effective integration of laser light sources with photosensitive elements enhances product performance

Achieved High-Precision Detection

Fully utilizes the unique excellent directionality and visual recognition of lasers, with ultra-small light spots (minimum 1mm), ensuring the precision of product detection.

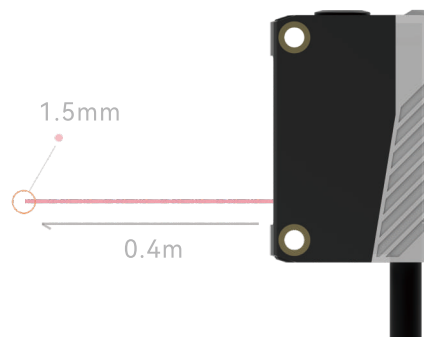

Fine Adjustment at Will

Adjustable knob for sensitivity adjustment, making it more convenient to use

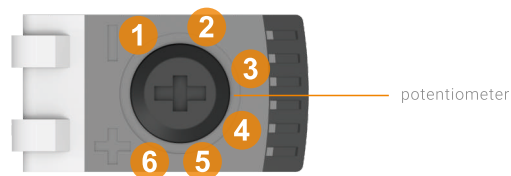

- Fiber Optic
- Slot Sensors
- Photoelectric
- Laser
- Proximity
- Displacement
- Magnetic
- Contact
- Area
- Ultrasonic
- AI Image
- Code Readers
- Vibration
- Temperature
- RFID
- Safety door lock
- Pressure Switch
- Communication
- Accessories

Guidance

- Laser sensors
- Square

Application

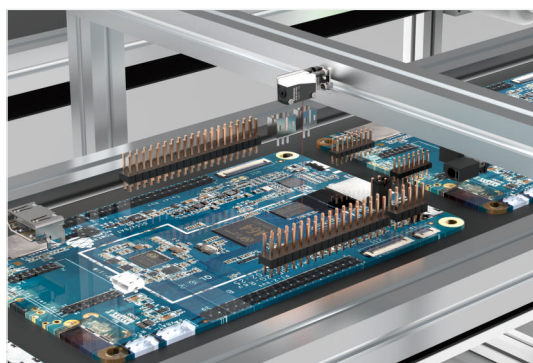

Detection of PCB boards on the production line

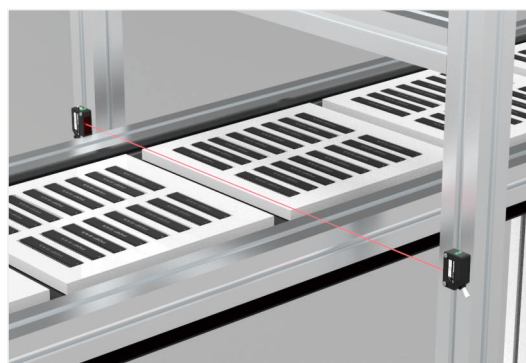

Checking if products inside packaging are correctly positioned

Guidance

Appearance	Type	Sensing Distance	Model No.		Pages
			NPN Normally open& Normally closed	PNP Normally open& Normally closed	
	Diffuse reflection	2~35cm	ELE-B35N	ELE-B35P	D-04
	Diffuse reflection	2~40cm	ELE-B35NS02	ELE-B35PS02	
	Diffuse reflection	2~80cm	ELE-D80NR	ELE-D80PR	
	Retro-reflection	10m	ELE-RM10AN	ELE-RM10AP	
	Thru-beam	50m	ELE-TM50AN	ELE-TM50AP	

- Fiber Optic
- Slot Sensors
- Photoelectric
- Laser
- Proximity
- Displacement
- Magnetic
- Contact
- Area
- Ultrasonic
- AI Image
- Code Readers
- Vibration
- Temperature
- RFID
- Safety door lock
- Pressure Switch
- Communication
- Accessories
- Guidance
- Laser sensors
- Square



Economical Type

NEW!



Basic Features	Working Principle	Photoelectric Sensor		
	Housing Style	Square		
	Optical Working Principle	Background suppression diffuse reflection		
	Detection Range	20~350mm	20~400mm	20~800mm
	Light Source	Red laser, 650nm (modulated), Class 2		
	Spot Size	Ø3.5mm/350mm	about Ø1.5mm/400mm	-
	Detected Object	Ø0.5mm		
	Indicator Light	Operating indicator light: green; Output indicator light: red		
	Sensitivity Adjustment	6-turn potentiometer		
Electrical data	Switching Mode	L.on (light-on action)/D.on (dark-on action) switchable		
	Output Mode	NPN or PNP collector open		
	Response Time	≤1.2ms		1.2ms
	Switching Frequency	1kHz	-	
	Repeatability	≤5%	-	
	Hysteresis	≤5%		
	Operating Voltage	10~24VDC ± 10%	10~30VDC ± 10%	
	Current Consumption	≤20mA		
	Residual Voltage	<1.5V		
	Load Current	≤100mA	100mA	
	Insulation Resistance	≥20MΩ(500V DC)	≥20MΩ(250V DC)	
	Withstand Voltage	1000VAC (50/60Hz)		
	Protection Circuit	Reverse polarity protection/short-circuit protection		Reverse connection protection/short-circuit protection
	Environmental conditions	Operating Temperature	-10~55°C(no freezing)	
Storage Temperature		-30~70°C(no freezing)		
Operating Humidity		35~85%RH(no condensation)		
Storage Humidity		35~95%RH(no condensation)		
Ambient Light		Incandescent light ≤1000 Lux; LED light ≤600 Lux; Sunlight ≤20000 Lux		
Vibration Resistance		10~55Hz, amplitude 1.5mm, 2 hours each in X/Y/Z axes		
Protection Rating		IP65		
Mechanical data	Maximum Tightening Torque	≤0.5Nm		
	Connection Method	2m/4-core cable		
	Dimensions	11.0x31.0x20.0mm		
	Material	PBT+glass fiber (housing); PMMA (lens)		
	Weight	about 68g		
	Accessories	Bracket, screws		
Model	NPN	ELE-B35N	ELE-B35NS02	ELE-D80NR
	PNP	ELE-B35P	ELE-B35PS02	ELE-D80PR

- Fiber Optic
- Slot Sensors
- Photoelectric
- Laser**
- Proximity
- Displacement
- Magnetic
- Contact
- Area
- Ultrasonic
- AI Image
- Code Readers
- Vibration
- Temperature
- RFID
- Safety doorlock
- Pressure Switch
- Communication
- Accessories

Guidance

Laser sensors

Square

Square

ELE Series



Economical Type

NEW!



Basic Features	Working Principle	Photoelectric Sensor		
	Housing Style	Square		
	Optical Working Principle	Retroreflective	Through-beam	
	Detection Range	10m	50m	
	Light Source	Red laser, 650nm (modulated), Class 2		
	Spot Size	≤15mmx15mm at 10m	≤25.5mmx29.1mm at 8m	
	Detected Object	≤0.5mm		
	Indicator Light	Operating indicator light: green, Action indicator light: red		
	Sensitivity Adjustment	Single-turn potentiometer		
	Electrical data	Switching Mode	L.on (light-on action)/D.on (dark-on action) switchable	
Output Mode		NPN or PNP collector open		
Response Time		≦1ms	≦1.7ms	
Switching Frequency		0.5kHz	0.3kHz	
Repeatability		≦5%		
Hysteresis		≦20%		
Operating Voltage		10~30VDC		
Current Consumption		≦20mA	Receiver: ≤20mA, Emitter: ≤10mA	
Residual Voltage		<1.5V		
Load Current		≦100mA(30VDC)		
Insulation Resistance		≧50MQ(500VDC)		
Withstand Voltage		AC 1000V 50/60Hz 60S		
Protection Circuit		Reverse polarity protection/short-circuit protection	Reverse polarity protection/ surge protection/short-circuit protection	
Environmental conditions		Operating Temperature	-25~55°C(no freezing/no condensation)	
		Storage Temperature	-30~70°C(no freezing)	
	Operating Humidity	35~85%RH(no condensation)		
	Storage Humidity	35~95%RH		
	Ambient Light	LED light ≤1000 Lux	Incandescent light ≤3000 Lux; LED light ≤3000 Lux	
	Vibration Resistance	10~50Hz, amplitude 0.5mm, 2 hours each in X/Y/Z axes		
	Protection Rating	IP67	IP65	
Mechanical data	Maximum Tightening Torque	≦0.5Nm		
	Connection Method	2m/3-core cable		
	Dimensions	11.0x31.0x20.0mm		
	Material	PBT+glass fiber		
	Weight	about 70g		
	Accessories	Screwdriver, reflector, mounting bracket, screws	Screwdriver, mounting bracket, screws	
Model	NPN	ELE-RM10AN	ELE-TM50AN	
	PNP	ELE-RM10AP	ELE-TM50AP	

ELE-B35/B35NS02/D80/RM10

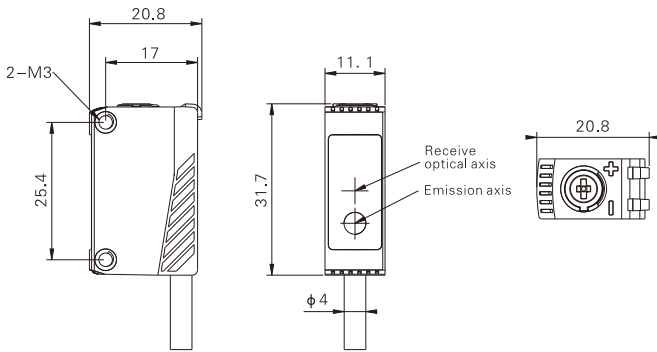

Reflector TD-11

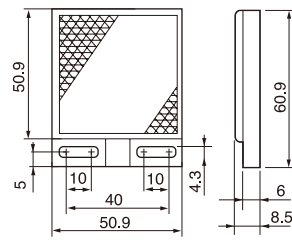

(ELE-RM10 Optional TD-11)

ELE-TM50

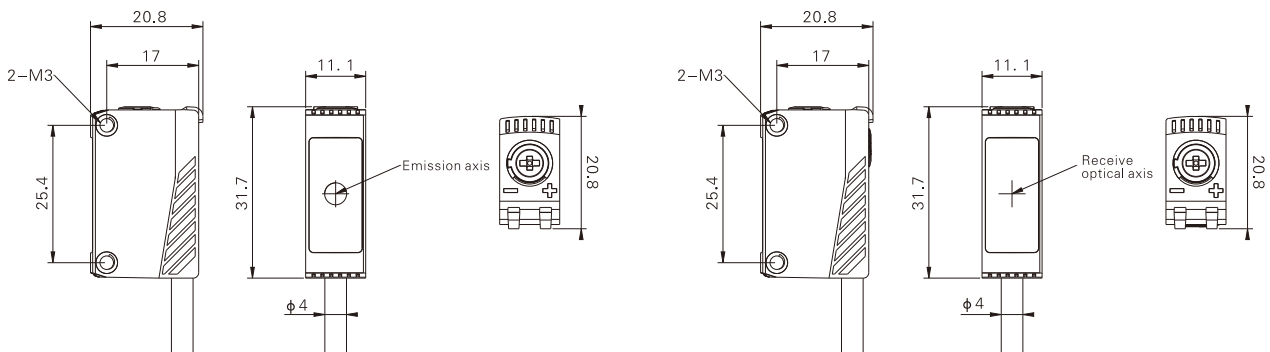

Circuit diagram

ELE-B35/B35N(P)S02/D80

NPN Output

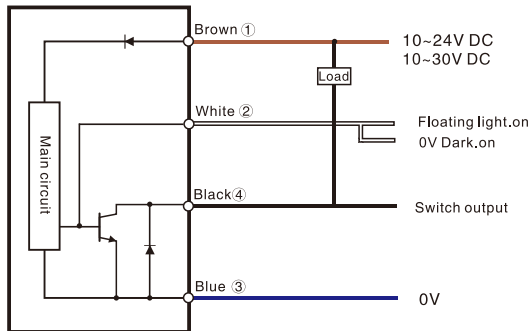

PNP Output

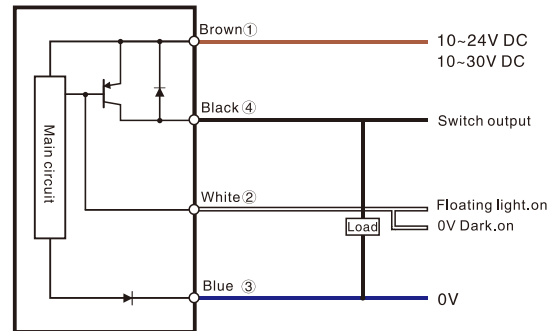

ELE-RM10/TM50

NPN Output

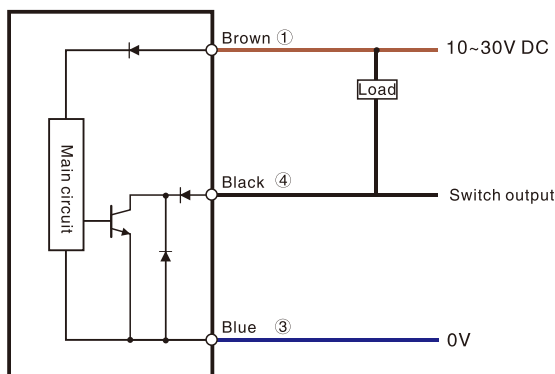

PNP Output

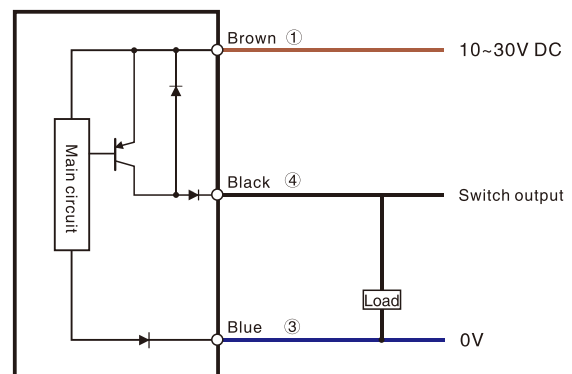

- Fiber Optic
- Slot Sensors
- Photoelectric

- Laser
- Proximity
- Displacement
- Magnetic
- Contact
- Area
- Ultrasonic
- AI Image
- Code Readers
- Vibration
- Temperature
- RFID
- Safety doorlock
- Pressure Switch
- Communication
- Accessories

Guidance

- Laser sensors
- Square