

Board Level Camera

The CB series board-level products is designed with a single board or multi-board stacked, which supports GigE or U3V protocol. It is applicable to the industrial, embedded, 3D, medical and other scenarios with more stringent space requirements.

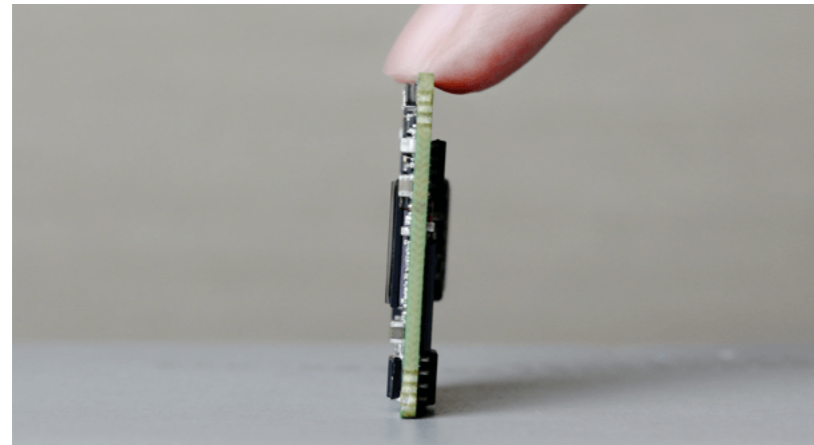

Ultra-small size, flexible for application

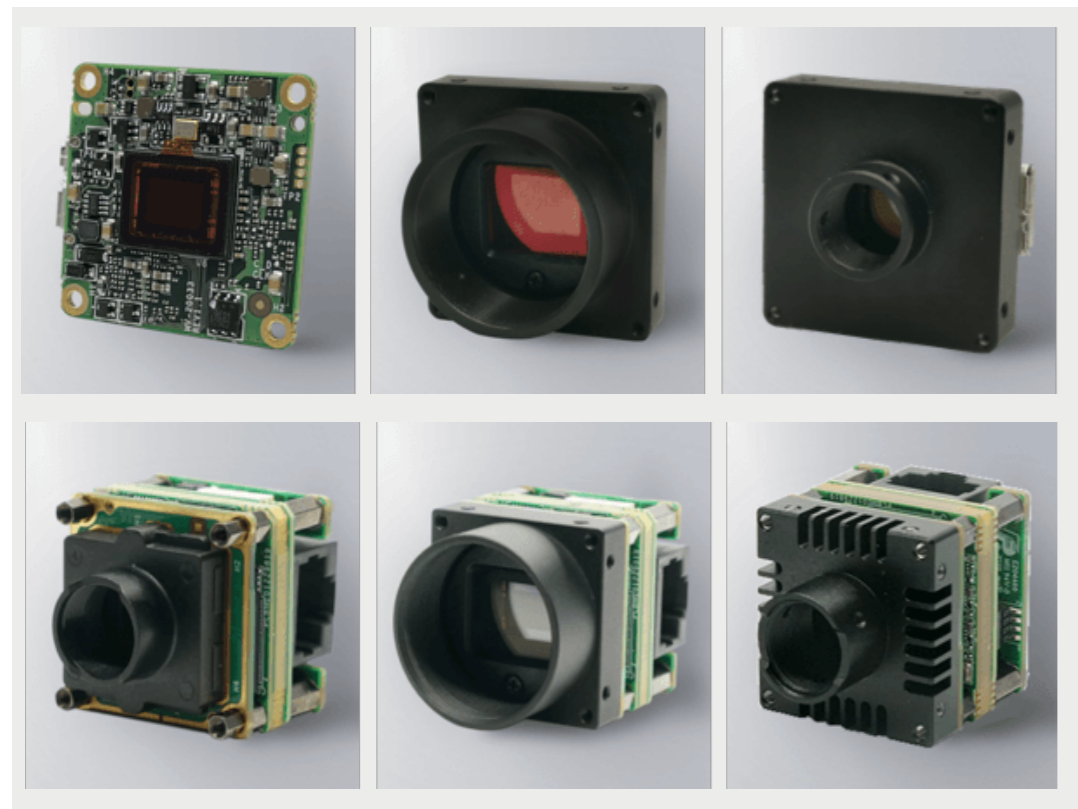

High-Bandwidth Mode, high line frequency transmission

CB Series GigE Board Level Camera



Specifications

Model	Sensor model	Sensor size	Pixel size	Shutter mode	Resolution	Max. frame rate	Exposure time	Power consumption	Label
MV-CB004-106M-S	IMX297	1/2.9"	6.9 μm	Global	720 × 540	125.2 fps	USE: 1 μs -14 μs NE: 15 μs -10 sec	Typ. 2.5 W@12 VDC	A
MV-CB016-106M-S	IMX296	1/2.9"	3.45 μm	Global	1440 × 1080	65.2 fps	USE: 1 μs -14 μs NE: 15 μs -10 sec	Typ. 2.6 W@12 VDC	A
MV-CB016-106C-C	IMX296	1/2.9"	3.45 μm	Global	1440 × 1080	65.2 fps	USE: 1 μs -14 μs NE: 15 μs -10 sec	Typ. 2.7 W@12 VDC	B
MV-CB060-106M-S	IMX178	1/1.8"	2.4 μm	Rolling	3072 × 2048	30.7 fps	NE: 25 μs -2.5 sec	Typ. 2.3 W@12 VDC	A
MV-CB060-106C-S	IMX178	1/1.8"	2.4 μm	Rolling	3072 × 2048	30.7 fps	NE: 25 μs -2.5 sec	Typ. 2.6 W@12 VDC	A

Notice: USE: Ultra-short exposure mode
NE: Normal exposure mode

Dimension

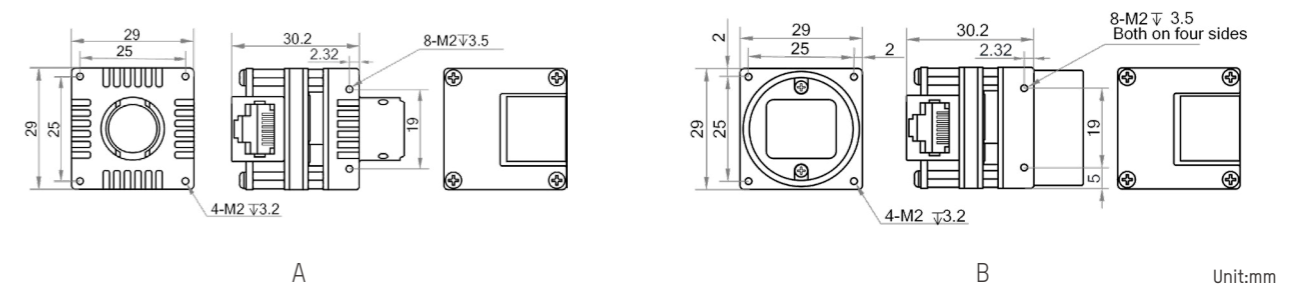

Unit:mm

■ CB Series USB3.0 Board Level Camera



Specifications

Model	Sensor model	Sensor size	Pixel size	Shutter mode	Resolution	Max. frame rate	Exposure time	Power supply	Label
MV-CB013-A0UM-B	HK	1/2"	4.8 μm	Global	1280 × 1024	201 fps	NE: 9 μs-10 sec	Typ. 1.6 W@5 VDC	A
MV-CB013-A0UM-C	HK	1/2"	4.8 μm	Global	1280 × 1024	201 fps	NE: 9 μs-10 sec	Typ. 1.6 W@5 VDC	B
MV-CB013-A0UM-S	HK	1/2"	4.8 μm	Global	1280 × 1024	201 fps	NE: 9 μs-10 sec	Typ. 1.6 W@5 VDC	C
MV-CB013-A0UC-C	HK	1/2"	4.8 μm	Global	1280 × 1024	201 fps	NE: 9 μs-10 sec	Typ. 2.8 W@5 VDC	B
MV-CB013-A0UC-S	HK	1/2"	4.8 μm	Global	1280 × 1024	201 fps	NE: 9 μs-10 sec	Typ. 2.8 W@5 VDC	C
MV-CB016-10UM-B *	IMX273	1/2.9"	3.45 μm	Global	1440 × 1080	249 fps	NE: 1 μs-10 sec	Typ. 2.5 W@5 VDC	A
MV-CB016-10UM-C *	IMX273	1/2.9"	3.45 μm	Global	1440 × 1080	249 fps	NE: 1 μs-10 sec	Typ. 2.5 W@5 VDC	B
MV-CB016-10UM-S *	IMX273	1/2.9"	3.45 μm	Global	1440 × 1080	249 fps	NE: 1 μs-10 sec	Typ. 2.5 W@5 VDC	C
MV-CB016-10UC-B *	IMX273	1/2.9"	3.45 μm	Global	1440 × 1080	249 fps	NE: 1 μs-10 sec	Typ. 2.5 W@5 VDC	A
MV-CB016-10UC-C *	IMX273	1/2.9"	3.45 μm	Global	1440 × 1080	249 fps	NE: 1 μs-10 sec	Typ. 2.5 W@5 VDC	B
MV-CB016-10UC-S *	IMX273	1/2.9"	3.45 μm	Global	1440 × 1080	249 fps	NE: 1 μs-10 sec	Typ. 2.5 W@5 VDC	C
MV-CB050-11UC-C	IMX264	2/3"	3.45 μm	Rolling	2448 × 2048	60 fps	USE: 1 μs-14 μs NE: 15 μs-10 sec	Typ. 2.8 W@5 VDC	D
MV-CB060-10UM-B	IMX178	1/1.8"	2.4 μm	Rolling	3072 × 2048	60.9 fps	NE: 8 us-1 sec	Typ. 1.5 W@5 VDC	A
MV-CB060-10UM-C	IMX178	1/1.8"	2.4 μm	Rolling	3072 × 2048	60.9 fps	NE: 8 us-1 sec	Typ. 1.5 W@5 VDC	B
MV-CB060-10UM-S	IMX178	1/1.8"	2.4 μm	Rolling	3072 × 2048	60.9 fps	NE: 8 us-1 sec	Typ. 1.5 W@5 VDC	C
MV-CB060-10UC-B	IMX178	1/1.8"	2.4 μm	Rolling	3072 × 2048	60.9 fps	NE: 8 us-1 sec	Typ. 1.8 W@5 VDC	A
MV-CB060-10UC-C	IMX178	1/1.8"	2.4 μm	Rolling	3072 × 2048	60.9 fps	NE: 8 us-1 sec	Typ. 1.8 W@5 VDC	B
MV-CB060-10UC-S	IMX178	1/1.8"	2.4 μm	Rolling	3072 × 2048	60.9 fps	NE: 8 us-1 sec	Typ. 1.8 W@5 VDC	C
MV-CB120-10UM-B	IMX226	1/1.7"	1.85 μm	Rolling	4032 × 3036	28 fps	NE: 11 μs-2 sec	Typ. 2.45 W@5 VDC	A

Model	Sensor model	Sensor size	Pixel size	Shutter mode	Resolution	Max. frame rate	Exposure time	Power supply	Label
MV-CB120-10UM-C	IMX226	1/1.7"	1.85 μm	Rolling	4032 × 3036	28 fps	NE: 11 μs-2 sec	Typ. 2.45 W@5 VDC	B
MV-CB120-10UM-S	IMX226	1/1.7"	1.85 μm	Rolling	4032 × 3036	28 fps	NE: 11 μs-2 sec	Typ. 2.45 W@5 VDC	C
MV-CB120-10UC-B	IMX226	1/1.7"	1.85 μm	Rolling	4032 × 3036	21 fps	NE: 23 μs-2 sec	Typ. 2.45 W@5 VDC	A
MV-CB120-10UC-C	IMX226	1/1.7"	1.85 μm	Rolling	4032 × 3036	21 fps	NE: 23 μs-2 sec	Typ. 2.45 W@5 VDC	B
MV-CB120-10UC-S	IMX226	1/1.7"	1.85 μm	Rolling	4032 × 3036	21 fps	NE: 23 μs-2 sec	Typ. 2.45 W@5 VDC	C

Notice: * will be released soon
 USE: Ultra-short exposure mode
 NE: Normal exposure mode

Dimension

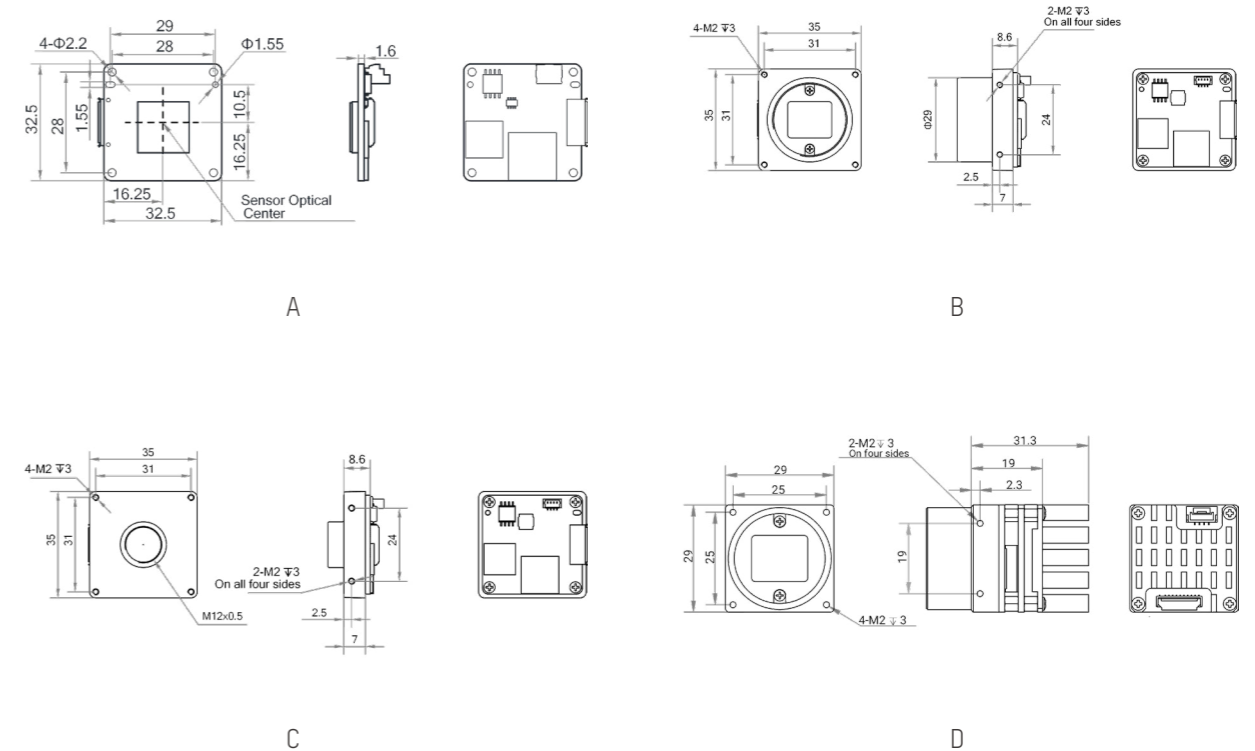

Unit:mm